

## Universal C-type Clamp (Wide Throat) Fig. 93 (Formerly Afcon Fig. 105)

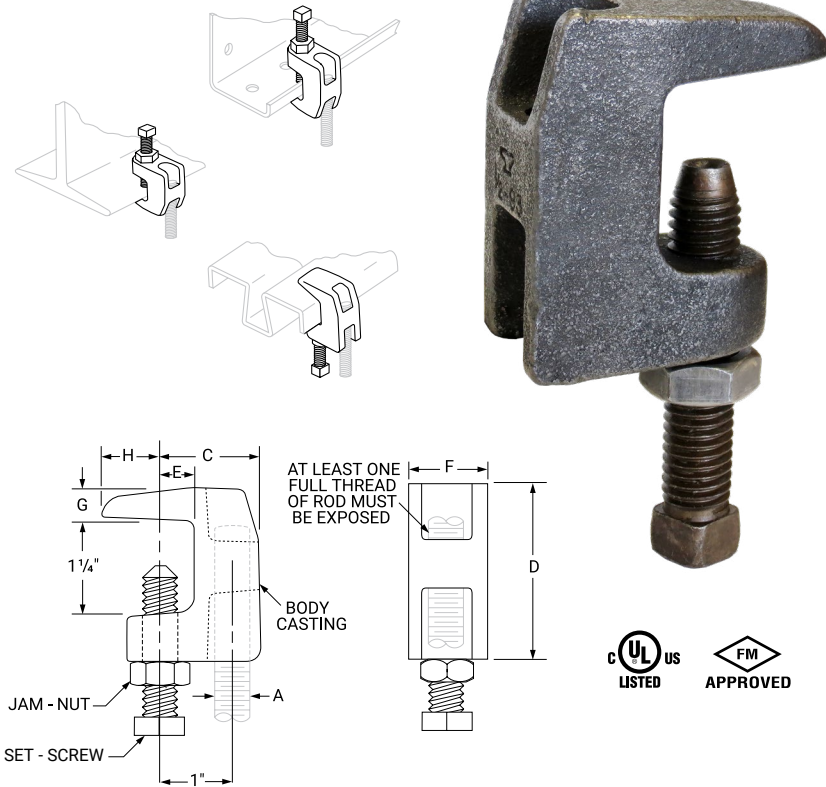

### Material Specifications

**Size Range**  
3/8" and 1/2"

**Material**  
Ductile iron, hardened steel cup point set screw and locknut.

**Finish**  
Plain  
Zinc Plated (Hot-Dip Galvanized optional)

**Service**  
Recommended for use under roof installations with bar joist type construction, or for attachment to the top or bottom flange of structural shapes where the vertical hanger rod is required to be offset from the edge of the flange and where the thickness of joist or flange does not exceed 1/4".

**Approvals**  
Complies with Federal Specification A-A-1192A (Type 19 & 23), WW-H-171-E (Type 23), ANSI/MSS SP-69 and MSS SP-58 (Type 19 & 23).  
UL, ULC Listed and FM Approved.

**How to size**  
Size of clamp is determined by size of rod to be used.

**Installation**  
Follow recommended set screw torque values per MSS-SP-69.

- Features**
- They may be attached to horizontal flanges of structural members in either the top beam or bottom beam positions.
  - Secured in place by a cup-pointed Set Screw tightened against the flange. A Jam Nut is provided for tightening the Set Screw against the Body Casting.
  - Thru tapping of the body casting permits extended adjustment of the threaded rod.
  - Wider throat for attaching to flange with up to 1/4" thickness.

**Ordering**  
Specify rod size, figure number, name of clamp and finish.

Available with oversized tapped rod hole for Hot Dip Galvanized finish.

### Dimensions (In) - Load (Lbs) - Torque (In-Lbs) - Weight (Lbs)

Rod Size A	Set Screw Size	Torque Value	Max Loads ■		Weight	C	D	E	F	G	H
			Top	Bottom							
3/8	3/8	60	500	250	0.41	1 5/16	2 5/32	9/16	13/16	3/8	5/8
1/2	1/2	125	950	760	0.75	1 3/8	2 11/32	1/2	1 1/16	7/16	13/16

**Note:**  
■ Maximum temperature of 450° F



PROJECT INFORMATION	APPROVAL STAMP
Project:	Approved
Address:	Approved as noted
Contractor:	Not approved
Engineer:	Remarks:
Submittal Date:	
Notes 1:	
Notes 2:	